

E025 MOBILE MIXING PLANT

OFF-ROAD VEHICLE B4X4



AGGREGATES
5 m ³
CEMENT
2500 Kg
H ₂ O
1500 L
EMULSION
300 L (opt.)
ADDITIVES
3 x 42 L (opt.)

B4x4: DIMENSIONS

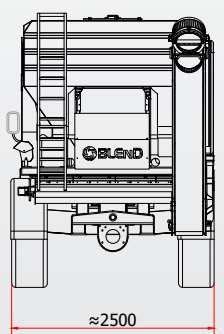
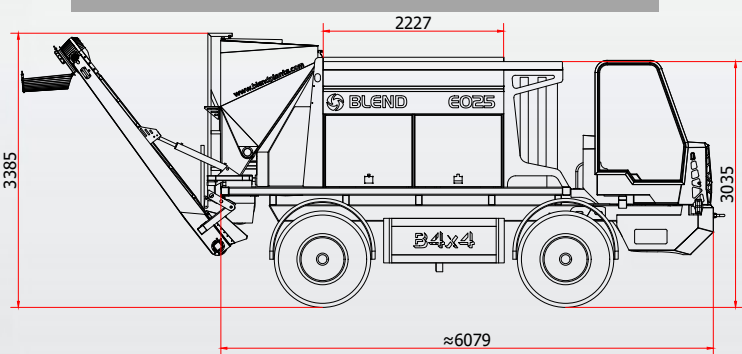
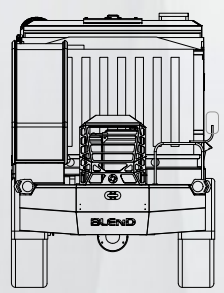

B4x4: PLACING BELT WORK

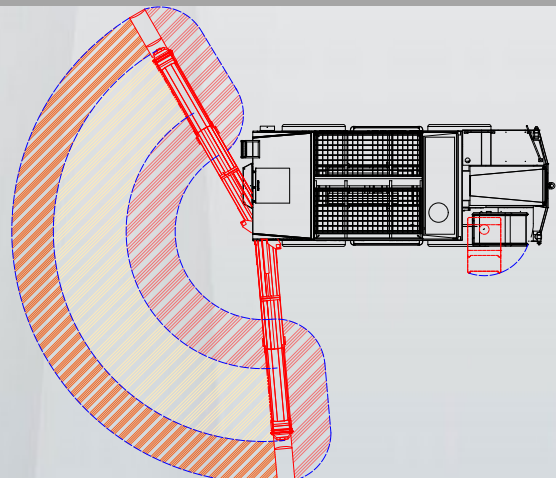

B4x4: STEERING RANGE

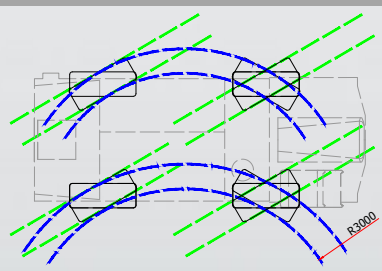



Diesel engine: PERKINS series 1104

Type: Turbo + Aftercooler 4400 cc , 4 in line

Cooling: Liquid

Maximum power: 100 kW 556 Nm

Rated speed: 2200 rpm

Emission standard: EU Stage IIIA / US EPA Tier 3 equivalent

MOBILE MIXING PLANT:

N°3 separate compartments: Aggregates, water & cement

Variable production output rate: the machine can produce, also while in movement, from 5 to 50 m³/h

Possibility to create & store 40 different recipes

Total volume delivered: 5 m³

ELECTRIC SYSTEM:

2 x 24V Batteries

Road light system, rear work lights.

4X4 FOUR-WHEEL DRIVE:

Hydrostatic “automotive” transmission with variable displacement pump and variable displacement hydraulic motor with electro-hydraulic control, and reverse gear control on the steering wheel.

Electro-hydraulically controlled mechanical gearbox for “working speed” and “road transfer” speed.

AXLES & WHEELS:

Front load-bearing, oscillating ($\pm 6^\circ$) and steering with planetary reduction gears on the wheel hubs.

Rear load-bearing and steering with planetary reduction gears on the wheel hubs and directly flanged gearbox.

Tyres: 18-22.5 PR

BRAKES:

Internal oil-bath disc service and emergency brakes acting on the 4 wheels, activation with mini-servo pump on independent dual circuit.

Negative type parking brake, with internal oil bath discs on the rear axle and electro-hydraulically controlled release.

STEERING:

Assisted by means of load-sensing power steering with double displacement on 4 steering wheels; steering selection device for: 2 steering wheels, 4 steering wheels - crab steering.

CAB:

Closed cab, designed in accordance with ROPS FOPS standards. 90° pivoting driving post.

Anatomic seat with flexible suspension.

Driving and equipment controls with ergonomic arrangement.

LCD TV display with camera for rear visibility.

SERVICE REFILL CAPACITIES:

Fuel tank: 120 litres

Total hydraulic system capacity: 135 litres

WEIGHTS:

Operating Weight: 6900kg

Maximum gross weight: 18500 kg