

EASYFLOOR P70

MOBILE PAVING SYSTEM

Model	P70
Pumping unit	HP95
Driven by	PTO
Chassis	4 axles



Dimensions

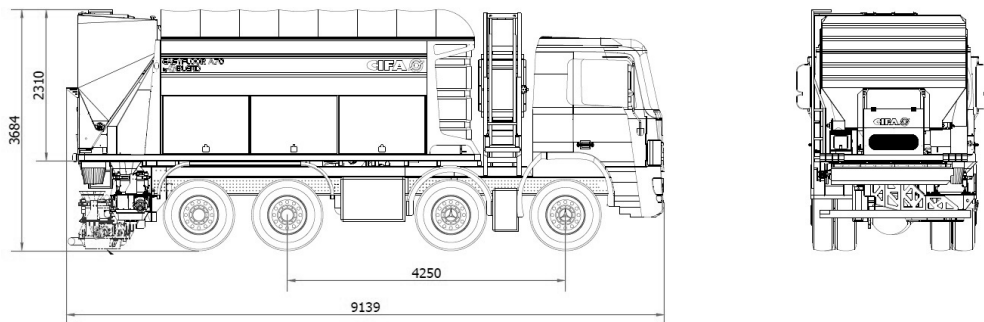

Dimensions varying according to truck assembly

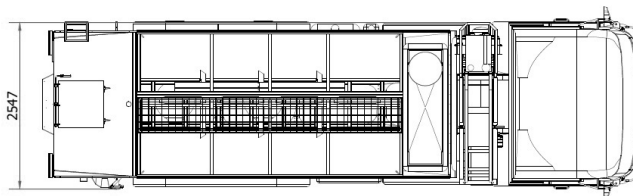

EASYFLOOR P70

Standard equipment

- Advantageous assembling on standard 4 axles chassis with self-supporting frame, torsion free, FEM designed
- Hopper of 14 mc for aggregate material with extracting belt
- 4 Vibrators on hopper's side with automatic temporisation
- Electric cover of the aggregate hopper
- Cement silos with wheight by loss dosing
- Cement vibrator
- Large water tank with dosing pump
- 2 Dosing pumps for liquid admixtures
- 1 Glass fiber dosing unit
- High efficiency
- Centralized lubrication system for dosing and mixing unit
- LED lights for illumination and blinking light
- High capacity tubing winder remote controlled
- Piston pumping unit with S-Valve
- Air connection for cleaning accesories
- High pressure water pump 35l /120 bar
- Cleaning hose complete with gun
- Project conforms to Directive Machinery 2006/42/CE
- Electronic control panel with USB port
- Printer
- Remote control for controlling production, mouvements and emergency stop
- Side storage compartments under lock and key
- Complies with the national industry 4.0 plan
- Bi-color paint CIFA orange-white

Control System

- Blend system
- Integrated color LCD
- Counters
- Concrete production management
- Diagnostic

Main Options

- Conveyor belt for direct discharge
- Telescopic conveyor belt for direct discharge
- Aggregate compartment divided into two independent hoppers
- Pneumatic loading for premixed material with built-in filtering system
- 3rd dosing pump for liquid admixtures
- Cement silo division divided into two independent silos

MOBILE PAVING SYSTEM

Model	P70
Pumping unit	HP95
Driven by	PTO
Chassis	4 axles

Pumping unit technical data

Model	P70	
8x4 Truck PTO		
Total required power	<i>Kw</i>	85
Max theoretical production	<i>Mc/h</i>	30
Max pressure	<i>bar</i>	50
Cycle per minute		30
Conc. cylinders (diam. x stroke)	<i>mm</i>	176x660
Inert storage capacity	<i>Mc</i>	~14
Cement capacity	<i>Mc</i>	4
Water tank capacity	<i>lit.</i>	2000
Additive tank capacity	<i>lit.</i>	2 x 42
Tube winder capacity	<i>mt</i>	100
Equipment weight	<i>Kg</i>	~4800

Technical data and characteristics subject to modifications without notice

